



# Surat Gas Project CSG Water Management Plan

<b>Version</b>	3.0
<b>Released</b>	April 2026
<b>Document Owner</b>	Concept Engineering Manager
<b>Document Author</b>	Principal Concept Engineer
<b>Review Date</b>	5 years from release date
<b>Document Status</b>	IFU
<b>Security Classification</b>	Routine

Please see document administration section for more information

# SGP CSG Water Management Plan

## Contents

<b>1.</b>	<b>Introduction</b>	<b>4</b>
<b>1.1</b>	<b>Location and Project Description</b>	<b>4</b>
<b>1.2</b>	<b>Purpose</b>	<b>4</b>
<b>1.3</b>	<b>Scope</b>	<b>6</b>
<b>1.4</b>	<b>Conformance Table</b>	<b>6</b>
<b>1.5</b>	<b>Project Approvals</b>	<b>7</b>
<b>1.6</b>	<b>DETSI CSG Water Management Policy</b>	<b>10</b>
<b>2.</b>	<b>Existing Environment</b>	<b>11</b>
<b>2.1</b>	<b>Climate</b>	<b>11</b>
<b>2.2</b>	<b>Surface Water</b>	<b>11</b>
<b>2.3</b>	<b>Groundwater</b>	<b>12</b>
<b>2.4</b>	<b>Terrain, Geology and Soils</b>	<b>12</b>
<b>3.</b>	<b>CSG Water Characterisation</b>	<b>14</b>
<b>3.1</b>	<b>CSG Water Quantity</b>	<b>14</b>
<b>3.2</b>	<b>CSG Water Quality Characteristics</b>	<b>19</b>
<b>3.3</b>	<b>CSG Water and Salt Management Strategy</b>	<b>22</b>
<b>3.4</b>	<b>Water Management Options</b>	<b>23</b>
<b>3.5</b>	<b>Brine and Salt Management Options</b>	<b>26</b>
<b>4.</b>	<b>SGP CSG Water Management Network</b>	<b>28</b>
<b>4.1</b>	<b>Conceptual Water Management</b>	<b>28</b>
<b>4.2</b>	<b>SGP Water Management</b>	<b>29</b>
<b>4.3</b>	<b>EA Specific Water Assets</b>	<b>32</b>
<b>5.</b>	<b>Risk Management</b>	<b>36</b>
<b>6.</b>	<b>Management Criteria</b>	<b>40</b>
<b>6.1</b>	<b>Measurable Criteria</b>	<b>40</b>
<b>6.2</b>	<b>Response Procedures</b>	<b>43</b>
<b>6.3</b>	<b>Arrow Operating Procedures</b>	<b>43</b>
<b>7.</b>	<b>Monitoring</b>	<b>44</b>
<b>7.1</b>	<b>Environmental Monitoring</b>	<b>44</b>
<b>7.2</b>	<b>Monitoring of CSG Water Management Dams</b>	<b>44</b>
<b>8.</b>	<b>Reporting</b>	<b>46</b>

## SGP CSG Water Management Plan

<b>8.1</b>	<b>Annual Return</b>	<b>46</b>
<b>8.2</b>	<b>Annual Inspection Report</b>	<b>46</b>
<b>8.3</b>	<b>Annual Monitoring Report</b>	<b>46</b>
<b>8.4</b>	<b>Incident Reporting</b>	<b>46</b>
<b>9.</b>	<b>Document Administration</b>	<b>47</b>

# SGP CSG Water Management Plan

## 1. Introduction

### 1.1 Location and Project Description

This Coal Seam Gas Water Management Plan (CWMP) is for Arrow Energy Pty Ltd.'s (Arrow) Surat Gas Project (SGP). The project development area is located approximately 160 km west of Brisbane in Queensland's Surat Basin and extends from the township of Wandoan in the north towards Millmerran in the south, in an arc through Dalby (Figure 1-1). The towns of Wandoan, Chinchilla, Kogan, Dalby, Cecil Plains, Millmerran, and Miles are located in or adjacent to the project development area.

The SGP will be a phased development over the approximate 30 year life of the project, including wells, gathering, compression facilities, processing facilities and associated supporting infrastructure. It considers the lifecycle Surat development, comprising both sanctioned and unsanctioned scope.

### 1.2 Purpose

The purpose of this CWMP is to:

- Address the requirements of section 126 of the EP Act as required for a site-specific EA application;
- Address Arrow's commitment under the Surat Gas Project Environmental Impact Statement (EIS) to produce a CWMP; and
- Describe how SGP's CSG water will be managed in a way that protects and maintains environmental values whilst balancing social and economic considerations.
- Support Arrow's Water Resource Monitoring and Management Plan, which forms part of Arrow's Environmental Protection and Biodiversity and Conservation (EPBC) approval

This CWMP has been prepared in accordance with the following Queensland Government regulatory guidance documents:

- The *Environmental Protection Act 1994* (Qld) (EP Act) – specifically Section 126 (1) and 126 (2); and
- The Department of Environment and Heritage Protection Coal Seam Gas Water Management Policy<sup>1</sup>; – specifically its prioritisation hierarchy for managing and reusing CSG water and for managing saline waste.

---

<sup>1</sup> Queensland Department of Environment and Heritage Protection (2012), Coal Seam Gas Water Management Policy.

# SGP CSG Water Management Plan

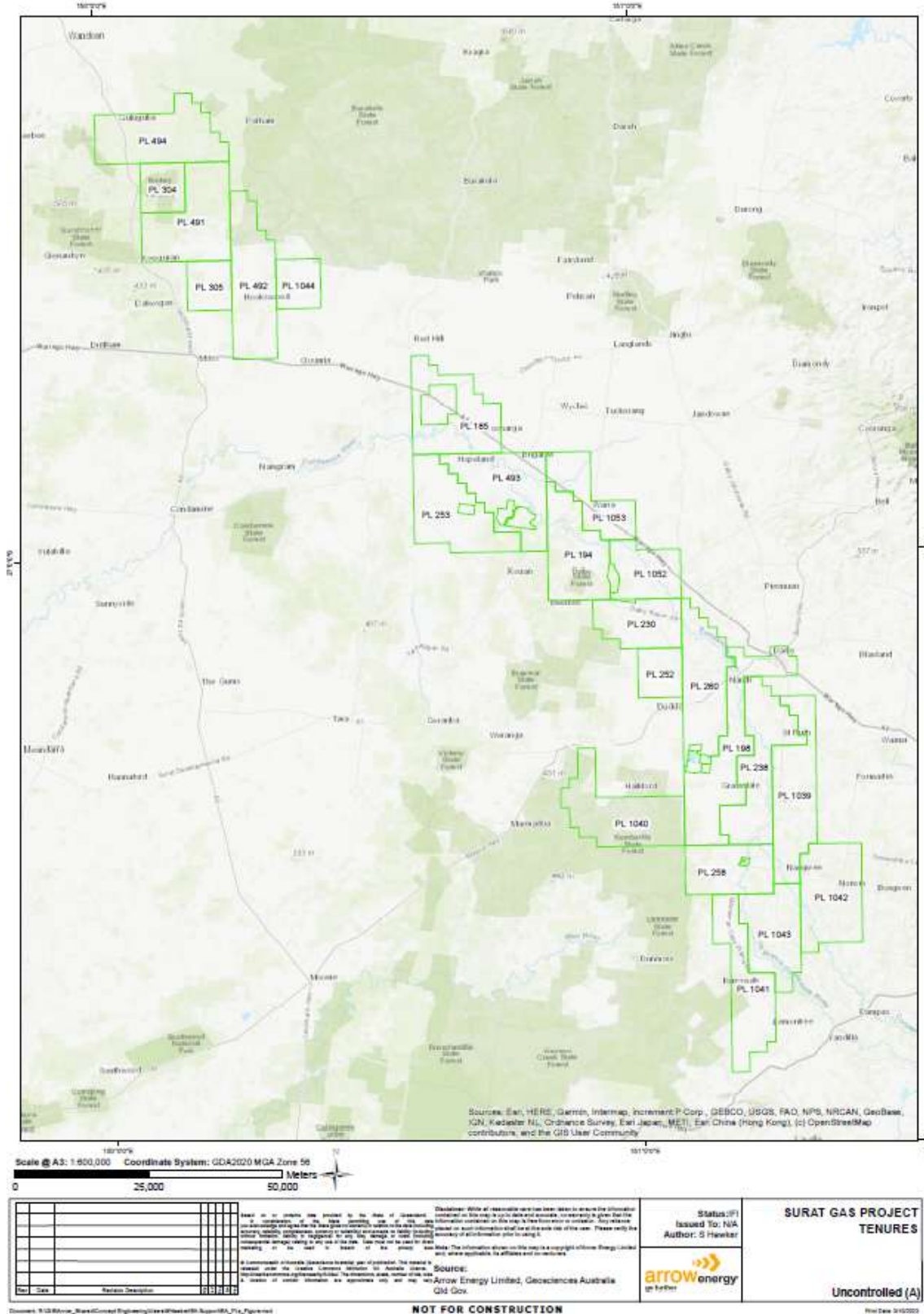

Figure 1-1 Surat Gas Project Tenures

# SGP CSG Water Management Plan

## 1.3 Scope

The scope of this CWMP includes:

- Characterisation of CSG water and the existing environment;
- Description of current and proposed CSG water management including the use, treatment, storage and beneficial use of water; and
- Description of procedures, controls and monitoring programs that minimise risk of CSG water management causing environmental harm.

The strategies for managing CSG water described in this CWMP align with Arrow Energy's broader vision for CSG water management in the Surat basin, as outlined in its Surat Gas Project CSG Water Management Strategy<sup>2</sup>.

## 1.4 Conformance Table

Table 1-1 lists specific CWMP regulatory requirements specified under Section 126 of the EP Act and identifies the relevant sections of the CWMP which address each specific requirement.

**Table 1-1 EP Act Conformance Table**

Requirement Under Section 126 of the EP Act	Relevant Section of CWMP
The quantity of CSG water the applicant reasonably expects will be generated in connection with carrying out each relevant activity.	Section 3.1
The flow rate at which the applicant reasonable expects CSG water will be generated.	Section 3.1
The quality of the water, including changes in the water quality that the applicant reasonably expects will happen while each relevant activity is carried out.	Section 3.2
The proposed management of CSG water including use, treatment, storage or disposal.	Section 3 and 4
The measurable criteria (the management criteria) against which the applicant will monitor and assess the effectiveness of water management including: <ul style="list-style-type: none"> <li>• The quantity and quality of the water used, treated, stored or disposed of.</li> <li>• Protection of environmental values affected by each relevant activity; and the disposal of waste, including, for example, salt.</li> </ul>	Section 6
The action proposed to be taken if any of the management criteria are not complied with, to ensure the criteria will be able to be satisfied in the future.	Section 6

<sup>2</sup> Arrow Energy (2017), Surat Gas Project CSG Water Management Strategy, Rev: 0, Doc No: ORG-ARW-ENV-STR-00001

# SGP CSG Water Management Plan

## 1.5 Project Approvals

Table 1-2 lists the status of Arrow Energy's CSG water management approvals applicable to the scope of this CWMP.

# Plan

S00-ARW-PMC-PLA-00169

Safe Work. Strong Business.



Table 1-2 Arrow Energy's CSG Water Management Approvals in the Surat Basin

Responsible Department	Area of Regulation	Requirement of Regulation	Environmental Authority	Project Name/Area	Tenure	Status
Department of the Environment, Tourism, Science & Innovation (DETSI)	CSG activities including CSG water management	Environmental Authority (EA)	EPPG00972513	Daandine Expansion Project	PL198	Granted
					PL230	Granted
					PL238	Granted
					PL252	Granted
					PL258	Granted
					PL260	Granted
			P-EA-100464322	Kogan North	PL194	Granted
			EA0001399	Surat Gas Project North	PL1044	Granted
					PL304	Granted
					PL305	Granted
					PL491	Granted
					PL492	Granted
			EA0001613	Surat Gas Project South	PL494	Granted
					PL1039	Granted
					PL1040	Granted
					PL1041	Granted
					PL1042	Granted
			EA0001401	Hopeland	PL1043	Granted
					PL185	Granted
			EA0001498	Surat Gas Project Kogan East	PL493	Granted
PL253	Granted					
EA0001540	Kenya Pipelines and Brine Dam	PL1052	Granted			
		PL1053	Granted			
EA0002214	McNulty Pipeline	PPL 2034	Granted			
EA0001473	David Pipeline	PPL2048	Granted			
EA0002659	Harry Pipeline	PPL2033	Granted			
EA0002166	Jammat Pipeline	PPL2052	Granted			
	Treated Water Return Pipeline	PPL2047	Granted			
		PPL 2058	Granted			

Once printed, this is an uncontrolled document unless issued and stamped Controlled Copy.



## SGP CSG Water Management Plan

Responsible Department	Area of Regulation	Requirement of Regulation	Environmental Authority	Project Name/Area	Tenure	Status
			P-EA-100740464	Surat Header	PL2060	Granted
		CWMP				Updated April 2026

### 1.6 DETSI CSG Water Management Policy

The CSG *Water Management Policy* (DEHP, 2012) outlines the Queensland Government’s position on the management of CSG water and guides CSG operators to consider the feasibility of using such water to meet the obligations of the EP Act as part of developing their CSG water management strategies and plans.

The policy aims to encourage the beneficial use of CSG water in a way that protects the environment and that maximises its productive use as a valuable resource. To achieve this, the policy outlines prioritisation hierarchies for managing and using CSG water, and for managing saline waste.

The policy focuses on the management and use of CSG water under the EP Act and does not change obligations from the Water Act 2000 (Water Act), including ‘making good’ any relevant impacts that may result from a CSG operation on water bores. Such measures executed under the Water Act may require the provision of water to mitigate impacts.

Arrow has adopted the Queensland Department of the Environment, Tourism, Science and Innovation (DETSI) prioritisation hierarchy as its starting point for determining the options for management of CSG water and brine. DETSI’s prioritisation hierarchies for CSG water and brine are presented in Figure 1-2. In accordance with the Policy, Arrow evaluates potential management options for water and brine against the prioritisation hierarchy, and implements Priority 1 options wherever feasible. Where Priority 1 options are not feasible, Priority 2 options are implemented. In determining the feasibility of options, factors that may be considered include technical and economic aspects in assessing identified options.

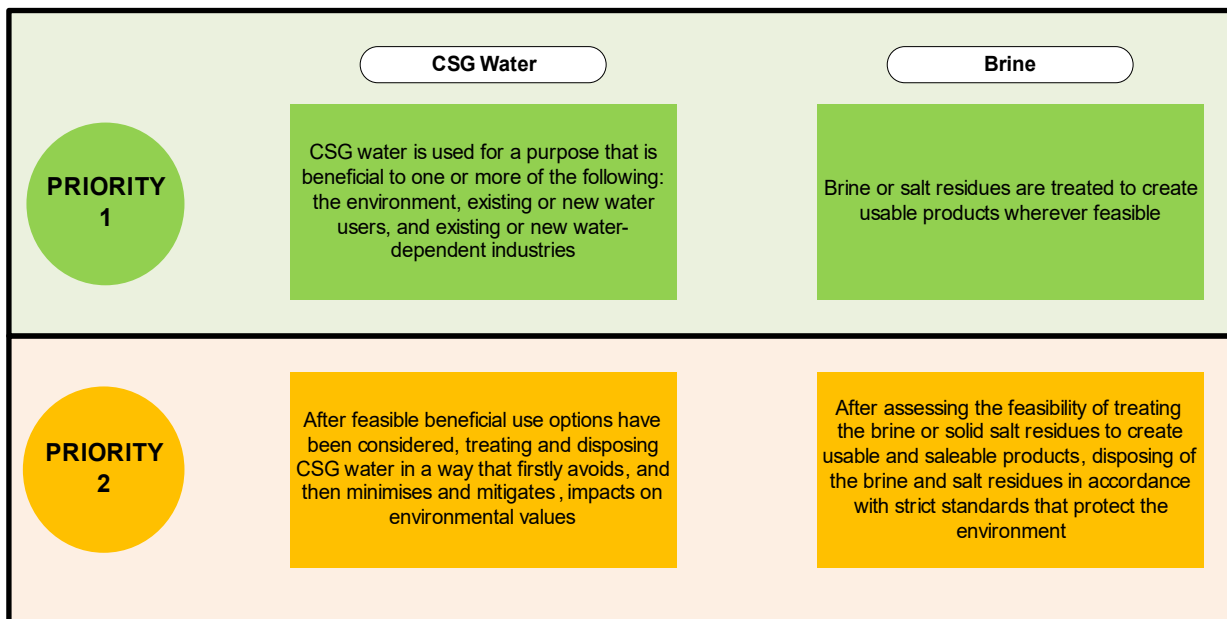

Figure 1-2 DETSI Prioritisation Hierarchies for CSG Water and Brine Management

## 2. Existing Environment

### 2.1 Climate

The Darling Downs has a warm climate typical of subtropical regions with mean temperatures in the project development area ranging from a mean monthly minimum of 3.6 in winter months (June to August) to a mean monthly maximum of 35°C in summer months (December to February).

The majority of rain falls between November and February. The average annual rainfall varies across the region and ranges from an average of 20 to 40 mm a month in winter, to 70 to 100 mm a month in summer. Around 20 thunderstorm days per year occur in the region, often involving strong winds, heavy rainfall and flooding.

### 2.2 Surface Water

Two regional drainage basins intersect the SGP development area: Condamine-Balonne Basin (Condamine River and Balonne River), Fitzroy Basin (Dawson River). The Condamine-Balonne forms part of the Murray-Darling drainage division, while the Fitzroy Basin is part of the North-East Coast drainage division.

Basins can be divided into sub-basins, with three sub-basins in the project development area: Balonne River, Condamine River and Dawson River. The Condamine is the predominant sub-basin within the project development area, accounting for over 50% of the total area.

The location or origin of each drainage basin is as follows:

- The Condamine- Balonne Basin forms the northern headwaters of the Murray-Darling river system;
- The Fitzroy Basin is located in central eastern Queensland and contains the Dawson River sub-basin. The Fitzroy River is formed by the confluence of the Dawson and MacKenzie rivers and then flows into the Coral Sea north of Rockhampton.

The project area is characterised by an extensive network of watercourses that are largely ephemeral, with varying geomorphic stream types that provide geomorphic diversity and contribute to habitat diversity. Rivers and creeks are generally intermittent, with surface waters in many streams receding to disconnected pools and dry beds during the dry season.

Potential water uses within catchments that include the SGP are:

- Agricultural (crop production and stock watering)
- Pastoral;
- Urban;
- Power generation;
- Mining; and
- Recreation.

## 2.3 Groundwater

The geology of the Surat Basin, in which the development is located, reflects approximately 200 million years of sedimentation producing a sedimentary sequence with up to a 2,500 m maximum depth. Geology underlying the project area consists of a sequence of interbedded aquifers and aquitards and is situated on the eastern section of the Great Artesian Basin (GAB).

The following groundwater systems have been identified in the vicinity of the project area (listed in order of increasing depth):

- Shallow groundwater system – Condamine Alluvium;
- Intermediate groundwater system – Gubberamunda Sandstone, Westbourne Formation and Springbok Sandstone;
- Coal seam gas groundwater system – Walloon Coal Measures; and
- Deep groundwater system – Hutton Sandstone, Evergreen Formation and Precipice Sandstone.

## 2.4 Terrain, Geology and Soils

### 2.4.1 Terrain

Topography of the SGP area is characterised by gently undulating land formed by fluvial deposition and erosion processes. Rock outcrops are present where resistance to erosion and channel scour has occurred. The underlying geology and geomorphic conditions have influenced the landscape and the area is characterised by the Great Dividing Range highlands, the Kumberilla Ridge uplands and two drainage basins, the Condamine-Balonne and Fitzroy.

### 2.4.2 Geology

Gas reserves within the SGP project area are primarily contained within the Walloon Coal Measures. The Walloon Coal Measures were formed during the Middle Jurassic period and are characterised by carbonaceous mudstone, siltstone, minor sandstone and coal. The geology of the Walloon Coal Measures comprises the following formations:

- Juandah Formation;
- Tangalooma Sandstone;
- Taroom Coal Measures; and
- Euromah Formation.

Only the Juandah Formation and Taroom Coal Measures are targeted for CSG production for the SGP.

### 2.4.3 Soils

Soil types across the SGP area have been classified under the Australian Soil Classification System and divided into seven broad types:

- Gilgai Clays - Occurring on flat to gently undulating terrain.
- Cracking Clays - Widespread across the Project area.

## SGP CSG Water Management Plan

- Uniform Non-cracking Clays - Occurring on gently undulating plains and rises, and upper slopes of hills.
- Texture Contrast Soils - Sharp textural contrast between surface and subsoil horizons of low agricultural value.
- Uniform Loams and Clays - Loams found along upper slopes whereas clay occur on lower slopes.
- Sands and Sandy Loams - Consists of alluvial and residual sands found on plains.
- Skeletal, Rocky or Gravelly Soils - Occur adjacent to rocky outcrops.

### 2.4.4 Land Use

The SGP is located within the Darling Downs, which is an important agricultural area. The land use in the area is strongly related to the different soil types and topography. Soils within the project development area are dominated by heavy clays, which form rich agricultural soil around the Condamine River. These soils are characterised by self-mulching, cracking clays with a deep profile. At higher elevations, shallow, gravelly soils are present.

Soil erosion is evident in areas where brigalow woodland has been extensively cleared. Agricultural land use within the project development area ranges from concentrated agriculture on the Condamine River floodplain, where many paddocks have been laser-levelled to achieve effective flood irrigation, through to cattle grazing in more marginal areas located to the north and west. Limited agricultural activity exists in areas of higher elevation and within state forests.

Current agricultural activities in the greater Darling Downs region include:

- Dryland broadacre farming;
- Irrigated broadacre farming;
- Horticulture;
- Fruit;
- Vineyards;
- Livestock industries; and
- Timber production.

## 3. CSG Water Characterisation

This section presents forecast CSG water production data and expected water quality.

### 3.1 CSG Water Quantity

CSG is the name given to naturally occurring gas trapped in underground coal seams by water and ground pressure. The gas lines the open fractures between the coal (called cleats) and the inside of the pores within the coal (the matrix). Coal seams store both gas and water. When the water pressure is reduced, the gas is released. In the production process, the water pressure is reduced when a well is drilled into a coal seam and the water is gradually pumped out of the seam. This allows the gas to flow to the surface via the well. CSG water production volumes and qualities vary considerably with location, well-spacing and coal seam depth. Water production forecasts fluctuate over time as a product of progressively commissioning and decommissioning wells to meet Gas Sale Agreements. For these reasons, forecasts for the timing, volumes and quality of CSG water production are updated as required, typically on a monthly basis. Production forecasting involves the following steps:

1. Developing key assumptions such as expansion areas, gas sales targets and gas usage for production activities;
2. Simulating the required production rates using a reservoir engineering model;
3. Developing and maintaining well program based on forecast timing; and
4. Reviewing model performance against actual production data and history matching.

Figure 3-1 presents the CSG water production forecast for the SGP. The forecast indicates that approximately 282 GL of water will be produced between 2026 and 2047. Since the start of the SGP in 2020, approximately 32GL of water has been produced. Forecast water production peaks at approximately 21 GL/yr, with average production of 13 GL/yr. Water production will diminish from the peak until project completion in approximately 2047.

# SGP CSG Water Management Plan

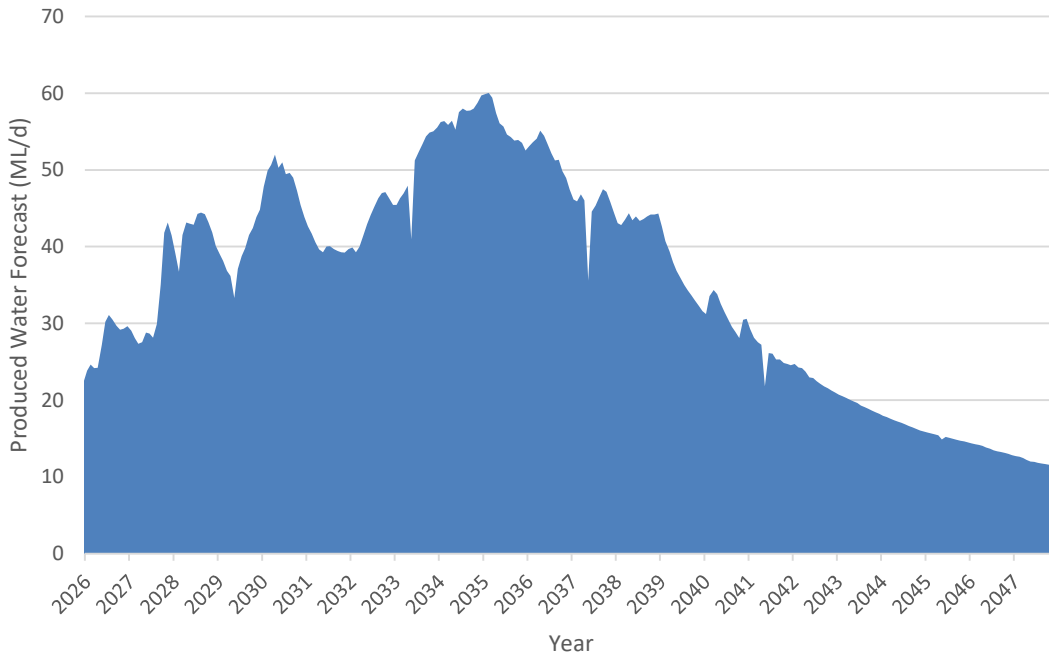

**Figure 3-1 SGP Water Production Forecast**

At the time of writing, the produced water forecast per Environmental Authority is as follows.

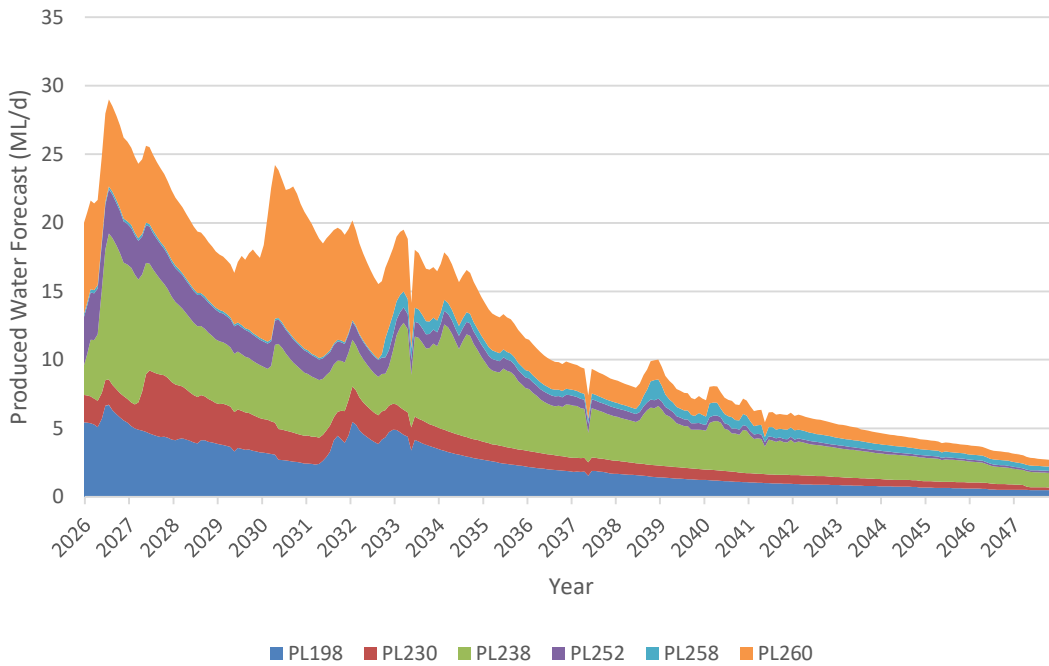

**Figure 3-2 Daandine Expansion Project Environmental Authority (EPPG00972513)**

# SGP CSG Water Management Plan

Based on the current field development plan, the Daandine Expansion Project will produce an average of ~4.4 GL/year CSG water between 2026 and 2047, with a total production of 97 GL. The peak production rate is estimated at 9.2 GL/year.

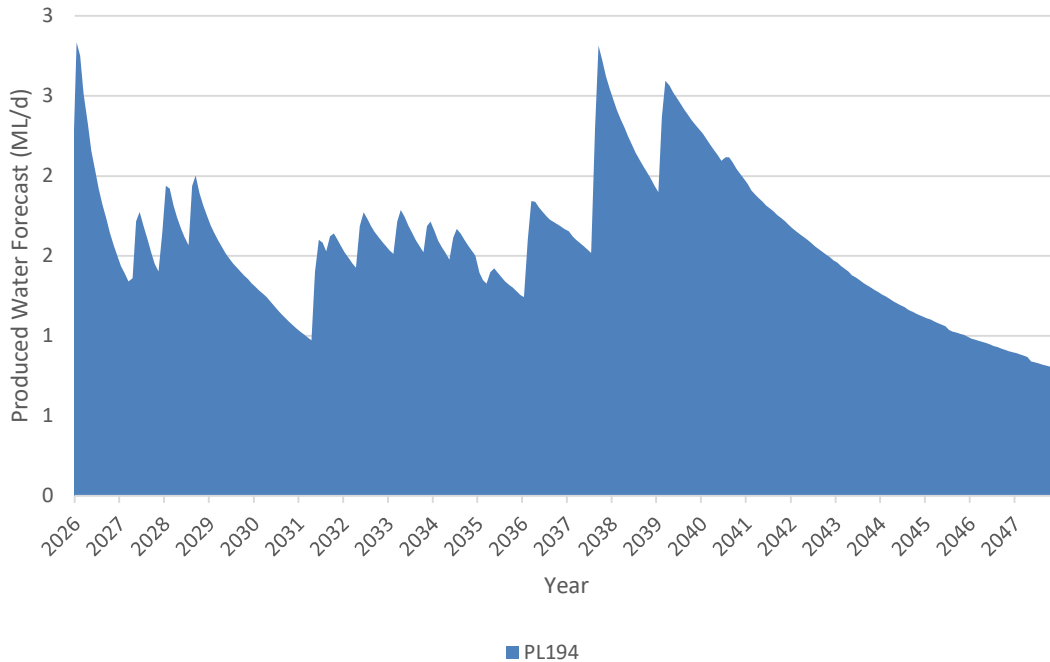

**Figure 3-3 Kogan North Environmental Authority (P-EA-100464322)**

Based on the current field development plan, the Kogan North development will produce an average ~0.6 GL/year CSG water between 2026 and 2047, with a total production of 12 GL. The peak production rate is estimated at 0.9 GL/year.

# SGP CSG Water Management Plan

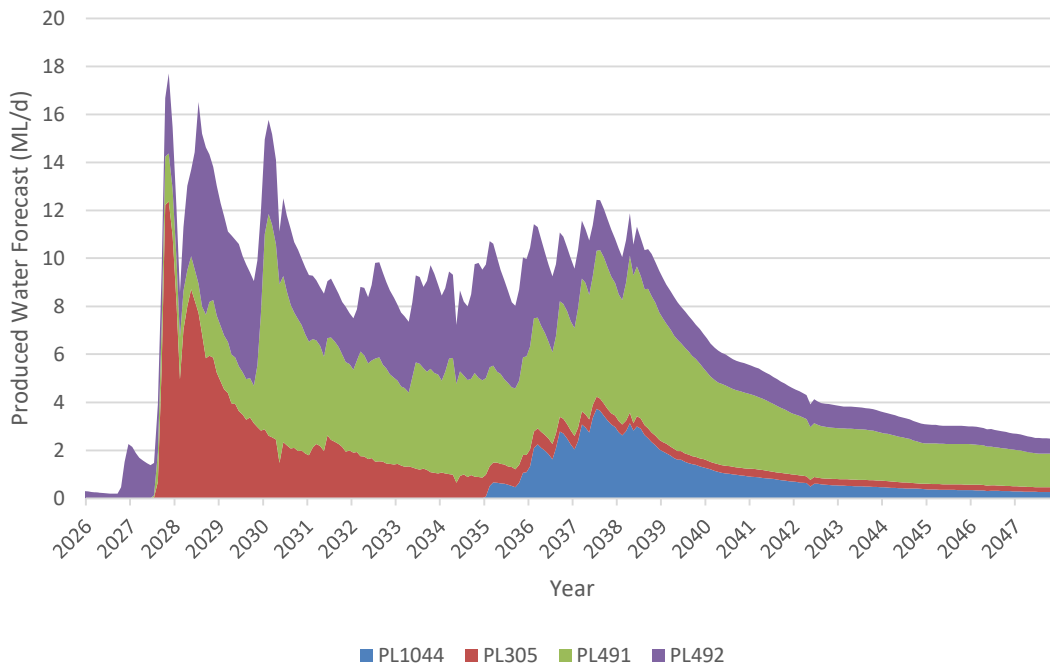

**Figure 3-4 SGP North Environmental Authority (EA0001399)**

Based on the current field development plan, the SGP North development will produce an average ~2.6 GL/year CSG water between 2026 and 2047, with a total production of 57 GL. The peak production rate is estimated at 4.9 GL/year.

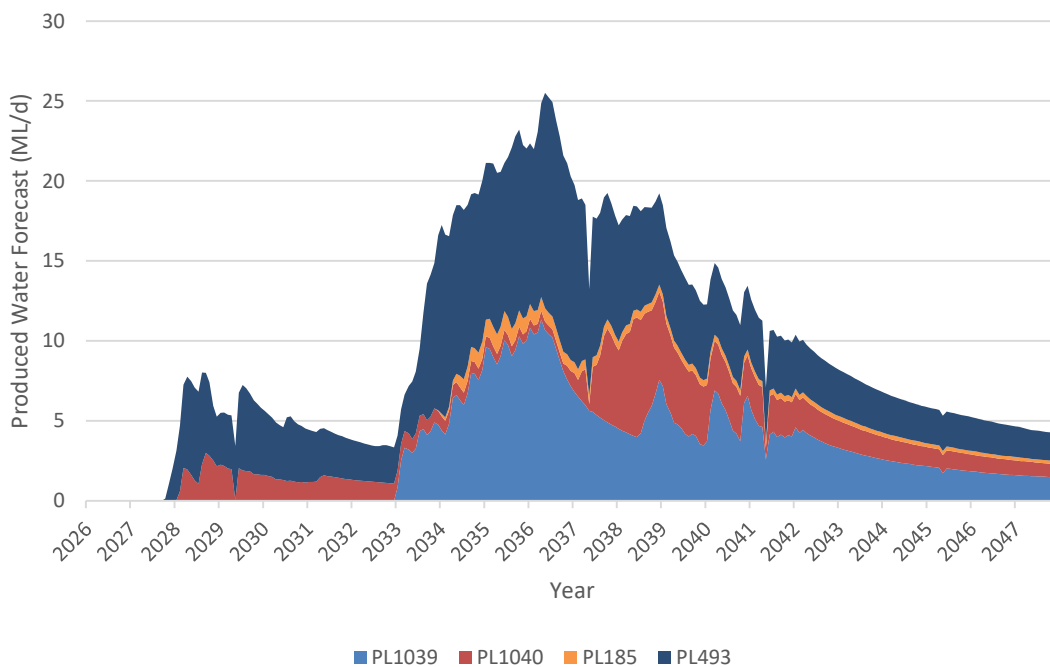

**Figure 3-5 SGP South Environmental Authority (EA0001613)**

## SGP CSG Water Management Plan

Based on the current field development plan, the SGP South development will produce an average ~3.7 GL/year CSG water between 2027 and 2047, with a total production of 77 GL. The peak production rate is estimated at 8.5 GL/year.

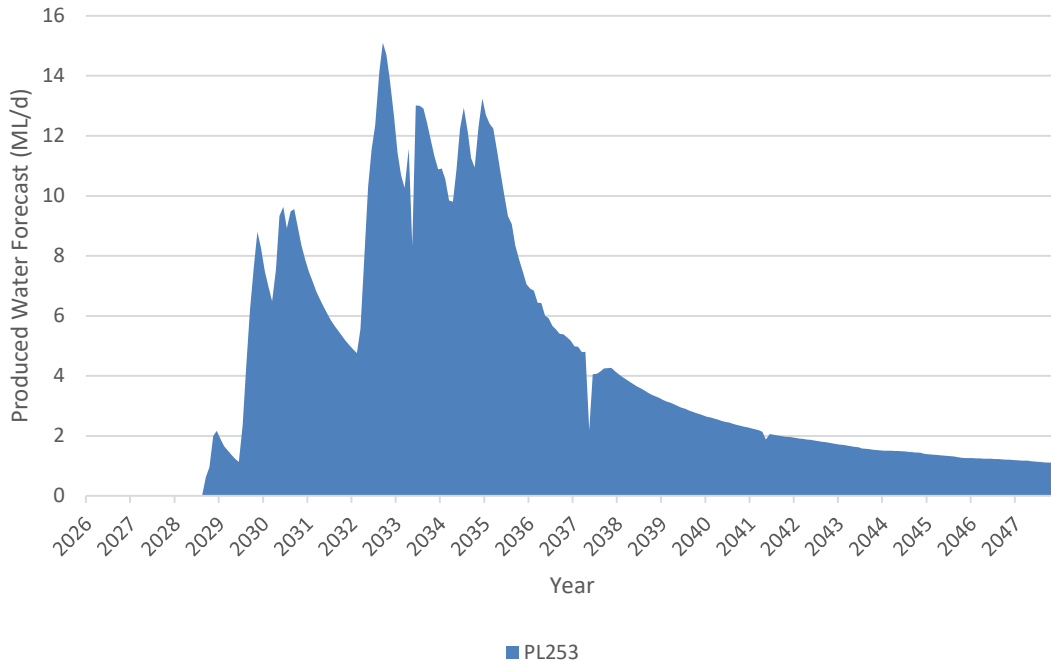

**Figure 3-6 Hopeland Environmental Authority (EA0001401)**

Based on the current field development plan, the Hopeland development will produce an average ~1.7 GL/year CSG water between 2028 and 2047, with a total production of 34 GL. The peak production rate is estimated at 4.2 GL/year.

# SGP CSG Water Management Plan

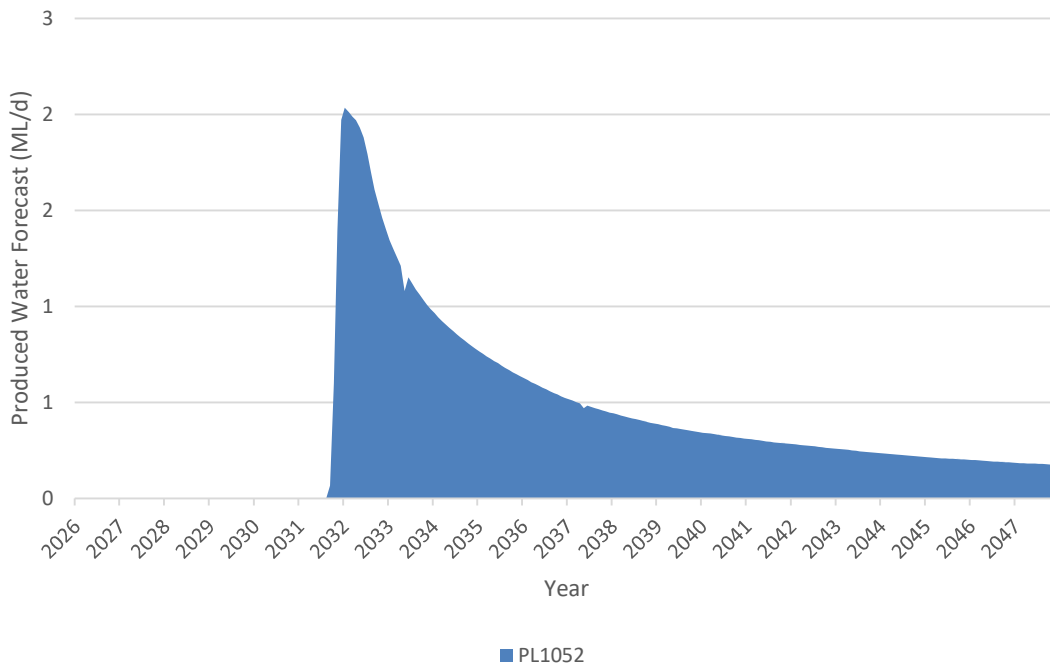

**Figure 3-7 SGP Kogan East Environmental Authority (EA0001498)**

Based on the current field development plan, the Kogan East development will produce an average ~0.2 GL/year CSG water between 2031 and 2047, with a total production of 3 GL. The peak production rate is estimated at 0.7 GL/year.

## 3.2 CSG Water Quality Characteristics

The SGP targets the Walloon Coal Measures. CSG water quality in these formations varies from slightly brackish to brackish. The water typically has the following characteristics:

- pH of approximately 8.5 to 9.5;
- Salinity in the range of 5,000 to 13,000  $\mu\text{S}/\text{cm}$  (i.e. brackish);
- Suspended solids that will usually settle out over time;
- Trace metals and low levels of nutrients.

Table 3-1 presents a summary of expected water quality for wells across the SGP development area. CSG water quality may vary over the life of a well, however significant variations have not been seen to date within fields of same geographical area.

**Table 3-1 SGP Expected Water Quality**

Parameter	Unit	LOR	10%ile	Median	90%ile
<b>Stream Properties</b>					
pH Value	pH Unit	0.01	8.86	9.14	9.38
Electrical Conductivity @ 25°C	$\mu\text{S}/\text{cm}$	1	5640	8660	13060
Total Dissolved Solids @180°C	mg/L	10	3190	4620	7550

## SGP CSG Water Management Plan

Parameter	Unit	LOR	10%ile	Median	90%ile
Suspended Solids (SS)	mg/L	5	9	34	80.5
Dissolved Organic Carbon	mg/L	1	4.1	16	37.9
Total Organic Carbon	mg/L	1	8	22	64.1
Silicon as SiO <sub>2</sub>	mg/L	0.1	10.3	18.2	21.23
Reactive Silica	mg/L	0.1	7.186	16.6	19.24
Nitrite as N	mg/L	0.01	<LOR	<LOR	<LOR
Nitrate as N	mg/L	0.01	<LOR	<LOR	0.03
Nitrite + Nitrate as N	mg/L	0.01	<LOR	<LOR	0.03
Total Phosphorus as P	mg/L	0.01	0.15	0.55	1.228
Total Hardness as CaCO <sub>3</sub>	mg/L	1	31	41	55
Dissolved Oxygen	mg/L		1.48	1.91	3.97
<b>Anions</b>					
Hydroxide Alkalinity as CaCO <sub>3</sub>	mg/L	1	<LOR	<LOR	<LOR
Carbonate Alkalinity as CaCO <sub>3</sub>	mg/L	1	254.6	440	751
Bicarbonate Alkalinity as CaCO <sub>3</sub>	mg/L	1	910.8	1090	1250
Total Alkalinity as CaCO <sub>3</sub>	mg/L	1	1340	1500	1900
Sulfate as SO <sub>4</sub> - Turbidimetric	mg/L	1	<LOR	<LOR	8.4
Chloride	mg/L	1	1540	2190	3540
Fluoride	mg/L	0.1	2.4	2.8	3.3
<b>Cations</b>					
Calcium	mg/L	1	7	9	12
Magnesium	mg/L	1	3	5	9
Sodium	mg/L	1	1626	2040	2884
Potassium	mg/L	1	6	10	15
<b>Total Metals</b>					
Aluminium	mg/L	0.01	<LOR	0.03	0.11
Arsenic	mg/L	0.001	<LOR	0.001	0.003
Beryllium	mg/L	0.001	<LOR	<LOR	<LOR
Barium	mg/L	0.001	1.136	1.4	1.92
Cadmium	mg/L	0.0001	<LOR	<LOR	<LOR
Chromium	mg/L	0.001	<LOR	<LOR	0.001
Cobalt	mg/L	0.001	<LOR	<LOR	<LOR
Copper	mg/L	0.001	<LOR	0.004	0.1584
Lead	mg/L	0.001	<LOR	<LOR	<LOR

## SGP CSG Water Management Plan

Parameter	Unit	LOR	10%ile	Median	90%ile
Lithium	mg/L	0.001	0.09	0.0965	0.1084
Manganese	mg/L	0.001	0.004	0.006	0.013
Molybdenum	mg/L	0.001	<LOR	<LOR	0.002
Nickel	mg/L	0.001	<LOR	<LOR	0.001
Selenium	mg/L	0.01	<LOR	<LOR	<LOR
Strontium	mg/L	0.001	1.85	2.56	4.36
Uranium	mg/L	0.001	<LOR	<LOR	<LOR
Vanadium	mg/L	0.01	<LOR	<LOR	<LOR
Zinc	mg/L	0.005	<LOR	<LOR	0.0134
Boron	mg/L	0.05	0.38	0.46	0.56
Iron	mg/L	0.05	<LOR	0.11	0.254
<b>Dissolved Metals</b>					
Aluminium	mg/L	0.01	<LOR	<LOR	0.01
Arsenic	mg/L	0.001	<LOR	<LOR	0.001
Beryllium	mg/L	0.001	<LOR	<LOR	<LOR
Barium	mg/L	0.001	0.7869	1.12	1.23
Cadmium	mg/L	0.0001	<LOR	<LOR	<LOR
Chromium	mg/L	0.001	<LOR	<LOR	<LOR
Cobalt	mg/L	0.001	<LOR	<LOR	<LOR
Copper	mg/L	0.001	0.003	0.0075	0.2432
Lead	mg/L	0.001	<LOR	<LOR	<LOR
Manganese	mg/L	0.001	<LOR	0.003	0.0067
Molybdenum	mg/L	0.001	<LOR	<LOR	0.001
Nickel	mg/L	0.001	<LOR	<LOR	0.002
Selenium	mg/L	0.01	<LOR	<LOR	<LOR
Strontium	mg/L	0.001	1.586	1.805	2.004
Vanadium	mg/L	0.01	<LOR	<LOR	<LOR
Zinc	mg/L	0.005	<LOR	<LOR	0.0074
Boron	mg/L	0.05	0.42	0.48	0.534
Iron	mg/L	0.05	<LOR	<LOR	<LOR

## 3.3 CSG Water and Salt Management Strategy

Arrow is committed to managing CSG water in a way that maximises beneficial use and that minimises environmental impact. To demonstrate this, Arrow has developed a Surat Gas Project Water Management Strategy<sup>3</sup> to ensure that the SGP manages water and salt consistently and within the Queensland Government regulatory framework. The strategy is supported by a series of plans and procedural documents to ensure that the following objectives are achieved:

- Communicate corporate policy and principles for the management of CSG water and salt;
- Align with the regulatory framework that applies to the:
  - Gathering, treatment, storage, distribution, beneficial use and disposal of CSG water and salt;
  - Monitoring and management of groundwater and predicted impacts to groundwater level changes in quality;
- Facilitate management of CSG water and salt in a way that maximises beneficial use and minimises the potential for environmental impacts; and
- Establish a framework for development of aquifer, surface water and infrastructure groundwater monitoring programs.

### 3.3.1 Water and Salt Management Options

Arrow CSG Water Management Strategy aligns with the DETSI CSG Water Management Policy as defined in Section 1.6.

To ensure that the most sustainable CSG water management portfolio is implemented, Arrow evaluates all strategy management options using a systematic and transparent multi-criteria assessment (MCA) process (refer Figure 3-8). The performance of each identified option is assessed against a set of weighted criteria and options selected as either “preferred”, “reserved” or “not preferred” based on the weighted score derived from the MCA.

Preferred options are prioritised for investment whilst reserved options continue to be evaluated through targeted feasibility studies. Non-preferred options are put on hold. To ensure that Arrow’s approach to CSG water utilisation remains reflective of the latest information, MCAs may be updated on a periodic basis.

---

<sup>3</sup> Arrow Energy (2017), Surat Gas Project CSG Water Management Strategy, Rev: 0, Doc No: ORG-ARW-ENV-STR-00001

# SGP CSG Water Management Plan

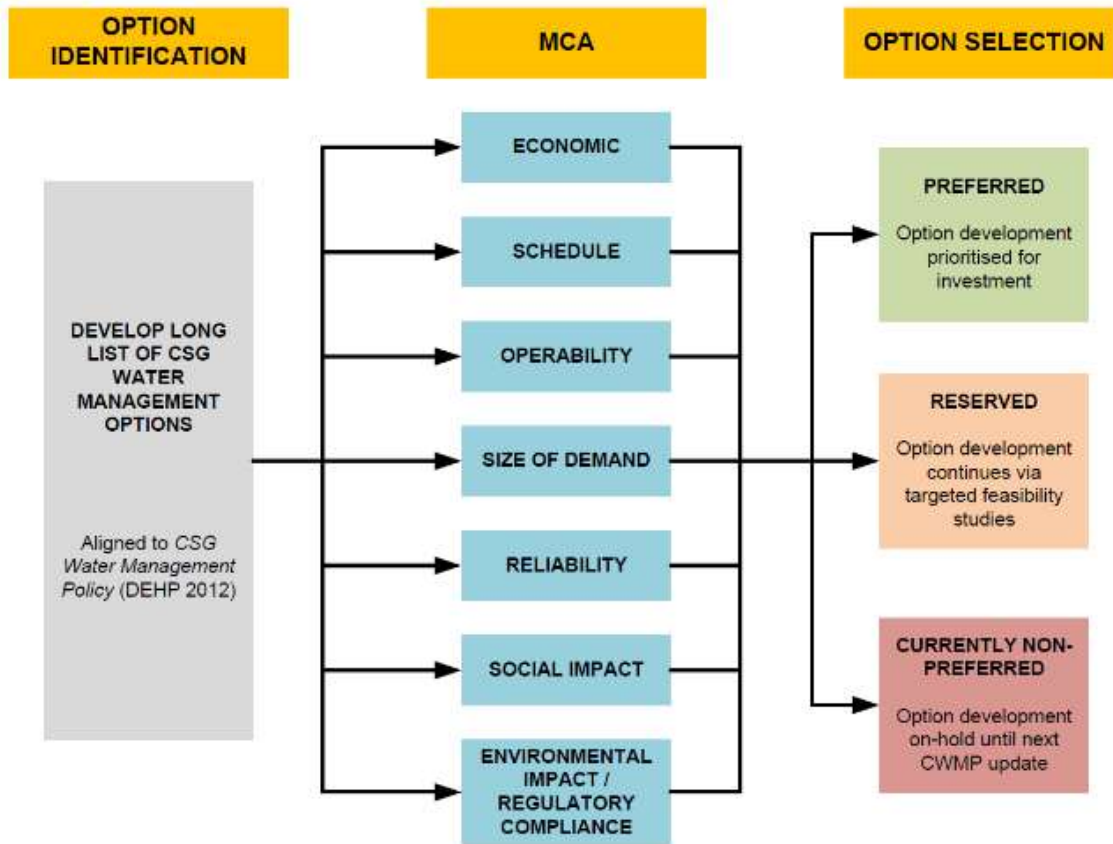

Figure 3-8 Option Selection and MCA Framework

## 3.4 Water Management Options

This section presents the water management options considered for the SGP. Saline waste management is discussed in Section 3.5.

Implementation of the preferred CSG water management options will result in the distribution of CSG water to a range of beneficial uses. Currently identified options are described below.

### 3.4.1 Agricultural Uses

Irrigation is the predominant and preferred water use within the SGP development area. Water supply options include servicing existing and new irrigators, substituting alternative irrigation water sources (including existing groundwater allocations). Notwithstanding this, the provision of water to new users or the expansion of existing uses is not considered a preferred management outcome, as CSG water availability is time-limited and may result in residual legacy impacts following cessation of supply.

Key considerations for providing CSG water to end users for irrigation include:

- The ability of end users to take large volumes of water regularly and reliably;

## SGP CSG Water Management Plan

- The location of end users in relation to the water treatment facility and distribution points (due to the cost of transporting water over large distances);
- The approvals framework;
- Users existing entitlements, storage and operations; and
- The appropriateness of the supply given the short-term nature of CSG water availability.

Responsibility for the water and any implications arising from its use rests with the end users. Arrow does not retain control over the use of water beyond the transfer point; however, Arrow will ensure that all regulations are met end users are informed of their obligations relating to approved uses and compliance with General Environmental Duties (GED)..

Where practical, Arrow's preferred management option for CSG water is beneficial use through substitution of existing groundwater allocations in the operating area. Substitution of allocations has the advantage that it constitutes both a beneficial means of managing produced CSG water, and a means of offsetting the potential impacts of Arrow's CSG production to bore owners with groundwater allocations.

Currently, there is no specific regulatory basis to facilitate substitution. Therefore, Arrow has developed a commercial scheme and worked with regulators to support the supply of treated CSG water to groundwater users who hold allocations. Under this scheme end users receive and utilise water supplied by Arrow in lieu of their groundwater allocations.

Arrow has committed to offsetting its portion of the predicted OGIA-modelled flux impacts to the Condamine Alluvium in areas of greatest predicted drawdown attributable to CSG water extraction from the Walloon Coal Measures.. This will be achieved through the installed beneficial use network that distributes water to groundwater users within specified areas of the Condamine Alluvium. The majority of Arrow produced water will be treated and substituted as part of the Arrow Condamine Alluvium Substitution Scheme (CASS).

### **3.4.2 Other Agricultural Uses**

Other potential agricultural beneficial uses include provision of water for livestock watering purposes (including feedlots) or for aquaculture.

### **3.4.3 Discharge**

Discharge of treated CSG water to watercourses is a reserved option in the event that other beneficial uses of CSG water are temporarily unavailable.

### **3.4.4 Urban Uses**

Urban supply remains a potential CSG water end use but is subject to further negotiation and a suitable supply arrangement that economically satisfies regulatory requirements.

### **3.4.5 Industrial Users**

Supply of CSG water to industrial users, predominantly for power stations within the Surat area.

# SGP CSG Water Management Plan

## 3.4.6 New Uses

Over the course of the SGP, water demands across areas in which Arrow operates will vary and it is anticipated that new opportunities for use of treated and untreated water may emerge.

Whilst Arrow may choose to evaluate any such opportunities in accordance with the adopted selection methodology (refer Section 3.3.1), supply to new users is not a preferred water management option. This is because the CSG water supply will only be available for a reasonably short period of time, and the development of new water reliant uses may result in potential legacy issues when CSG water is no longer available.

## 3.4.7 Aquifer Injection

Aquifer injection, either for re-pressurisation or as a means for CSG water management, is not currently proposed for the SGP due to the potential risks and the lack of an appropriate regulatory system.

## 3.4.8 Ocean Outfall

Disposal of CSG water to the sea via an ocean outfall pipeline is recognised as a technically feasible option, but currently non-preferred due to environmental and community concerns.

## 3.4.9 Alignment of Arrow and DETSI Priorities

A summary of the CSG water management options is presented in Table 3-2 which aligns Arrows preferred and non-preferred options with the DETSI prioritisation hierarchy.

**Table 3-2 CSG Water Management – Alignment of Arrow and DETSI priorities**

Arrow Priority	Option	Comments	DETSI Priority
Preferred	Arrow operational supply	Dust suppression, construction, potable etc.	Priority 1
	Substitution of allocations	Beneficial use to existing abstractors (virtual injection)	Priority 1
	Industrial supply to existing users	Non-Arrow use, where established	Priority 1
Reserved	Discharge to watercourse	Subject to Environmental Authority conditions	Priority 2
Non-preferred	MAR	Managed aquifer recharge	Priority 1
	Industrial supply to new users	Non-Arrow use, where established	Priority 1
	Urban water supply	Non-preferred by LGA due to cost of compliance	Priority 1

Arrow Priority	Option	Comments	DETSI Priority
	Ocean outfall	Non-preferred due to environmental and community concerns	Priority 2
	Deep aquifer injection	Currently no identified target aquifer	Priority 2

## 3.5 Brine and Salt Management Options

The preferred management options listed above largely require treatment to reduce water salinity to acceptable levels in accordance with DETSI approval conditions, resulting in a brine stream by-product.

Assuming an average salt concentration of 4,500 mg/L for water from the Walloons formation in the Surat Basin, treatment of CSG water via reverse osmosis ( to ~500 mg/L TDS) will generate in the order of 4 tonnes of salt per megalitre of treated water. Raw water feed concentrations vary across tenements and may also change over time within a given CSG field. Brine stream concentrations will therefore change accordingly.

Specific measures are required to manage the storage and use (or disposal) of brine. A range of brine management options are identified and described in the following sections.

### 3.5.1 Salt Recovery

The concentrated brine by-product of desalinated water from the Surat Basin coal measures is comprised primarily of sodium chloride, sodium carbonate and sodium bicarbonate salts. A range of options for salt recovery are under consideration for the SGP.

Any future Salt Encapsulation Facility (SEF) will be designed to the relevant legislation and guidelines at the time, and consider risks associated with location and integrity, and implementation of a monitoring system.

#### i. Non-selective salt recovery and SEF

Non-selective recovery can be undertaken in purpose designed, lined solar evaporation ponds, through other thermal processes, or using mechanical crystallisers. The mixed salt product recovered has little or no commercial value, therefore disposal of the solid product is required, by encapsulation of the solid salts in purpose designed cells.

#### ii. Selective salt recovery and SEF

SSR requires the selective crystallisation of salts from RO brine to provide separate end product streams – typically sodium chloride, sodium carbonate and sodium bicarbonate, enabling commercial opportunity for sale of the product. A waste salt by-product is also produced that is dependent on the chemical characteristics of the brine processed at the salt recovery facility and therefore still requires disposal.

SSR is currently a reserved option because work to date has demonstrated that the recovered salt product has only modest value and the market is fully supplied by existing low

# SGP CSG Water Management Plan

cost producers. Furthermore, the process is energy intensive and substantial transport distances to market would present issues of safety and cost. The combined energy and transport requirements would also result in high emissions intensity for the final product.

### 3.5.2 Brine Injection

Brine injection requires identification of a target formation with permeability and parameters sufficient to enable injection and storage, and where the water quality is such that injection of the brine will not impact the environmental values of the groundwater system.

To date, suitable aquifers have not been identified within Arrow’s Surat tenements, and brine injection is a non-preferred management option.

### 3.5.3 Ocean Outfall

As for water, disposal of brine to the sea via an ocean outfall pipeline is recognised as a technically feasible option, but is currently non-preferred due to environmental and community concerns.

### 3.5.4 Alignment of Arrow and DETSI Priorities

A summary of the brine and salt management options is presented in Table 3-3 which aligns Arrows preferred and non-preferred options with the DETSI prioritisation hierarchy.

**Table 3-3 CSG Brine Management – Alignment of Arrow and DETSI priorities**

Arrow Priority	Option	Comments	DETSI Priority
Preferred	Non-selective salt recovery and salt encapsulation facility	Solid product salt encapsulation facility in purpose designed regulated waste facilities	Priority 2
Reserved	Selective salt recovery and salt encapsulation facility	Currently uneconomic, unable to demonstrate a commercial market, has high emissions intensity and greater safety risk. Salt encapsulation facility remains required for waste salt by-products.	Priority 1
Non-preferred	Brine injection	Currently no identified target aquifer	Priority 2
	Ocean outfall	Non-preferred due to environmental and community concerns	Priority 2

## 4. SGP CSG Water Management Network

### 4.1 Conceptual Water Management

Management of CSG water will comprise six main process components:

1. CSG production wells and associated water gathering system;
2. Water transfer pipeline(s);
3. Aggregation dam(s);
4. Water Treatment Plants (WTP);
5. Treated water dam(s) and associated beneficial use offtakes; and
6. Brine dam(s).

Figure 4-1 provides a conceptual diagram of this process.

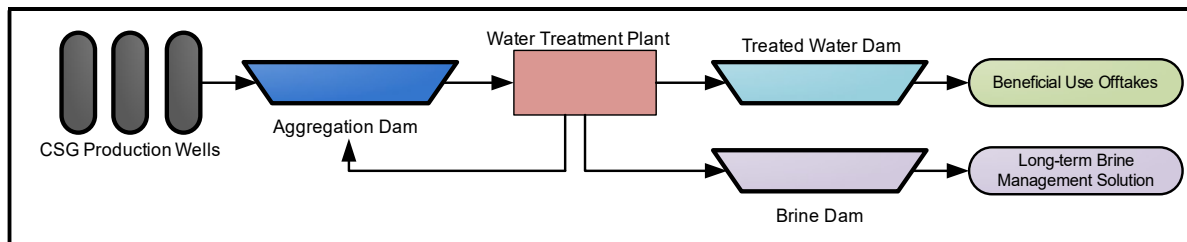
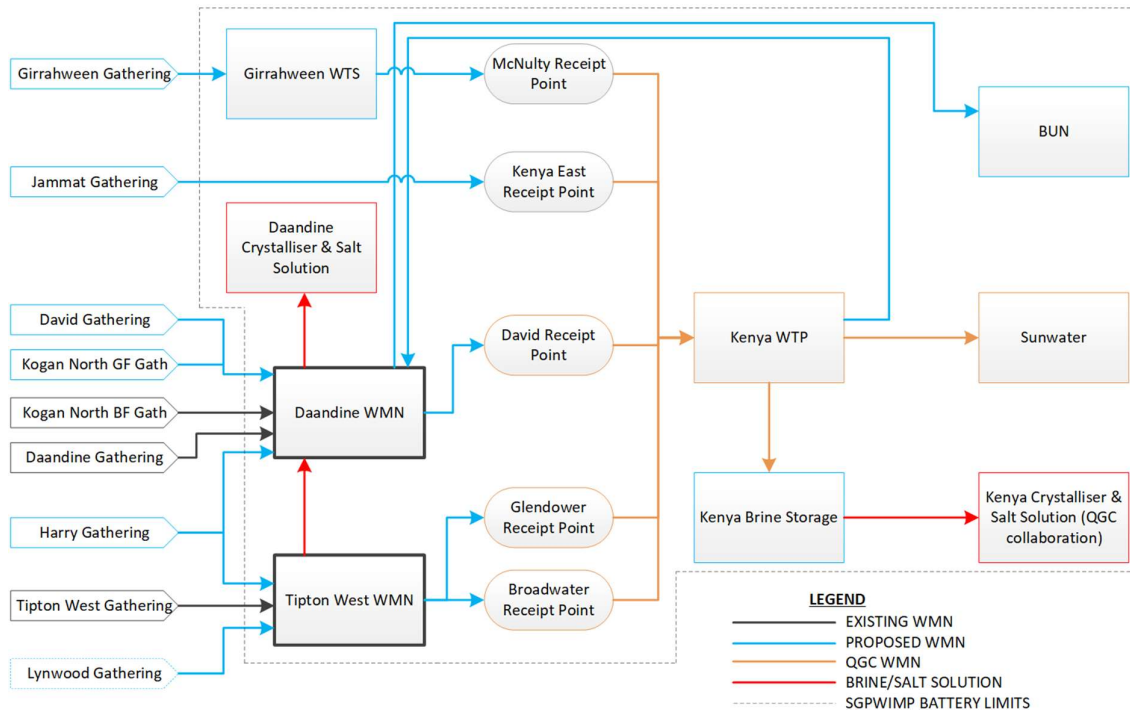

**Figure 4-1 Conceptual Diagram of CSG Water Management**

## 4.2 SGP Water Management

The water management scheme for the SGP comprises a number of assets and agreements to manage the CSG water originating from the Arrow tenures. Figure 4-2 provides an overview of the integrated SGP water management network.

Arrow has entered into a Water Services Agreement (WSA) with QGC, to utilise QGC infrastructure to manage Arrow CSG water. This includes the use of existing QGC dams, treatment plants and irrigation infrastructure. These assets are approved and managed in accordance with QGC’s Environmental Authorities. The majority of water produced by the SGP will be transferred to the Arrow-QGC receipt points, minimising the need for investment in new Arrow facilities infrastructure.



**Figure 4-2 Proposed SGP CSG Water Management Network**

The management of CSG water through each main asset type is discussed in the following sub-sections.

### 4.2.1 CSG Water Gathering and Transfer Pipelines

CSG water is gathered via a network of buried HDPE low pressure pipes to a downstream facility for management.

Arrow has two existing brownfield facilities, Daandine and Tipton.

Daandine receives produced water from the DXP, Kogan North, Kogan East and parts of the SGP South development areas. Produced water is transferred from the Daandine Feedwater Dam to QGC’s David Pond, for management within the QGC network, or retained for local treatment by the Daandine WTP. In addition, Daandine plans to receive water from the Demineralisation Plant treatment process at the nearby Braemar 2 Power Station.

## SGP CSG Water Management Plan

Tipton receives produced water from the DXP and parts of the SGP South development areas. Produced water is transferred from the Tipton Feedwater Dam to QGC's Broadwater and Glendower Ponds, for management within the QGC network, or retained for local treatment by the Tipton WTP.

The brownfield Kogan North development produces water to the Kogan North Dam. Prior to entering the dam, water can be pumped to a number of beneficial users or transferred to the Daandine Feedwater Dam. Water which is not diverted is discharged into the Dam. The greenfield Kogan North development will produce water directly to the Daandine Facility

CSG water from the initial southern part of the SGP North development will be discharged directly to QGC's McNulty Pond for management within the QGC network. Once the gathering has extended to the Girraheen Facilities area, comprising the Girraheen FCS and Girraheen Water Transfer Station (WTS), the gathering will be redirected to the Girraheen WTS and pumped to QGC's McNulty Pond via a dedicated transfer line. The Girraheen WTS is supported by an upstream Feed Tank.

Produced water generated by the Hopeland development will be discharged to QGC's Kenya East Pond.

### 4.2.2 CSG Water Treatment

Arrow operates two Water Treatment Plants, one at Daandine and the other at Tipton. Both plants utilise a process of Microfiltration (MF) and Reverse Osmosis (RO). MF is a microporous membrane separation process with selectivity on the basis of the size of the particle. Most MF membranes are screen filters with the feed inlet pressure serving as the driving force for filtration. The membranes allow the removal of turbidity, bacteria, cysts and particulates from the water to sizes of 0.1 to 3 µm. Following MF, water is treated using RO to remove dissolved salts. RO is significantly more complex than MF and involves the separation of salts from solution through a semi-permeable, microporous membrane under elevated hydrostatic pressure creating a permeate stream of treated CSG water and a brine waste stream containing concentrated salts.

QGC's Kenya Water Treatment Facility (WTF) uses similar technologies to treat CSG water originating from Arrow tenures.

### 4.2.3 CSG Water Storage

Water storages provide buffer between management processes, and long term storage of waste products. Water is stored primarily in dams, with tanks utilised where a short process buffer is required.

Arrow defines its dams as follows:

- **Aggregation Dams** – contain CSG water from gathering network. Aggregation dams provide a buffer to address variations in CSG water production and water treatment capacity.
- **Treated Water Dams** – contain treated CSG water. Treated water dams provide a buffer between treatment plant output and beneficial use demand.

## SGP CSG Water Management Plan

- **Central Gas Processing Facility (CGPF) and WTP Utility Dams** – contain waste lubricants and chemicals used in treatment and compression systems.
- **Brine Dams** – contain brine produced from the reverse osmosis water treatment process.

Arrow's SGP development comprises the following dams:

- The Daandine water management network includes seven (7) dams.
- The Tipton water management network includes seven (7) dams
- The SGP North development includes three (3) existing appraisal dams
- The SGP South development includes one (1) existing appraisal dams
- The Hopeland development includes one (1) existing appraisal dams
- The Kenya Pipelines and Brine Dam includes one (1) dam with approval for one (1) future dam

### 4.2.4 Beneficial Use

As detailed above in Section 3.4, the preferred DETSI CSG water management strategy is beneficial use. Across the SGP, the most substantial beneficial use option is irrigation. Other major beneficial use options include supply to industrial users (power stations or coal mines) and intensive livestock (feedlots, piggeries). Selection of beneficial use options requires careful consideration of the predicted water volumes, stakeholder requirements and Arrow's approval obligations.

Arrow's preferred management option for CSG water is beneficial use through substitution of existing Condamine Alluvium (CA) groundwater allocations. Under this scheme end users receive and utilise water supplied by Arrow in lieu of their groundwater allocations. Arrow has committed to offsetting its component of modelled likely flux impacts to the Condamine Alluvium in the area of greatest predicted drawdown as a result of CSG water extraction from the Walloon Coal Measures and is conditioned to do so under its Federal environmental approval.

The Condamine Alluvium Substitution Scheme (CASS) has been established with a number of Condamine users to assist Arrow meet obligations and it's offset target based on OGIA modelling. The users have agreed to seasonally assign their CA allocation to Arrow (and not utilise it) in return for that same (plus an allowance for losses) volume of Arrow treated water. The permitted purpose of this supply is irrigation.

The CASS is physically implemented through the Beneficial Use Network (BUN) constructed to distribute treated water to groundwater users within specified areas of the Condamine Alluvium. Users connected to the network will receive water from Arrow's Daandine facility as well as a proportion of Arrow's water treated at the QGC Kenya facility. Arrow's treated water from the Kenya facility (originating from the CSG water transfers to the QGC receipt points) will be provided back to the Arrow BUN via the Treated Water Return Pipeline (TWRP), which discharges into the Daandine facility. Any remaining Arrow treated water from Kenya will be supplied to the existing SunWater beneficial use scheme which connects Kenya to the Chinchilla weir, with associated end users along the pipeline.

## SGP CSG Water Management Plan

Treated water distributed to the CASS is supplied under the relevant EA. Other beneficial use offtakes are supplied per the conditions in the relevant EA or by using the relevant End of Waste Code. Treated water specifications from all of the water treatment facilities meet the requirements of these approvals.

A small portion of produced water may selectively be used by Arrow for construction purposes, dust suppression and operational and maintenance purposes, or may be supplied for industrial uses (e.g. coal mines or power stations) or stock watering.

### **4.2.5 Contingency Discharge**

Arrow is currently licensed under the DXP EA to release treated CSG water to Wilkie Creek. Arrow is committed to maximising beneficial use of its CSG water prior to disposal methods and thus discharge to Wilkie Creek is held as a contingency measure to adapt to seasonal fluctuation in irrigation demand or to preserve dam integrity during excessive rainfall. The infrastructure required to facilitate discharge to Wilkie Creek has not yet been constructed.

### **4.2.6 Brine and Salt Management**

Water treatment processes that include desalination, such as reverse osmosis, produce a brine stream by-product. The resulting brine is stored in purpose-built brine storage dams until such time as Arrow selects a brine management solution. A range of brine management options have been identified and are described above in Section 3.5.

QGC's Kenya WTF includes a secondary brine concentration technology, thermal brine concentrators, to minimise the brine stream and thereby reduce the number of required brine storage dams.

Whilst a long-term salt solution has not been selected, the preferred option (refer Section 3.5) for managing the residual stored brine at the Daandine and Tipton Facilities is currently to crystallise the brine to a solid waste salt product near the Daandine facility, and then to dispose of this waste at a dedicated salt encapsulation facility (location to be confirmed). Brine stored at the Tipton facility will be transferred to Daandine in the future for crystallisation. As the required infrastructure is not required for a number of years, alternative salt management options will be periodically reviewed to confirm the selected option.

Similarly, the preferred option for brine produced at the Kenya WTF, from water transferred to the various Arrow-QGC transfer receipt points, is crystallisation of the brine to a solid waste salt product near the Kenya facility, and then to disposal of this waste at a dedicated salt encapsulation facility (location to be confirmed). As the required infrastructure is not required for a number of years, alternative salt management options will be periodically reviewed to confirm the selected option.

## **4.3 EA Specific Water Assets**

The water infrastructure per EA, which comprises the SGP is outlined within this section.

### **4.3.1 Daandine Expansion Project Water Management Network**

The DXP WMN contains the following water assets, in addition to water gathering and transfer pipelines.

# SGP CSG Water Management Plan

**Table 4-1 Daandine Water Management Network Storages**

Dam Name	Type	Volume at Design Storage Allowance (ML)	Volume at Mandatory Reporting Level (ML)	Volume at Spillway (ML)
Daandine Aggregation Dam	Aggregation	1,166	1,239	1,458
Daandine Feedwater Dam	Aggregation	392	418	458
Daandine Treated Water Dam	Treated	199	208	238
Daandine Brine Dam	Brine	1,045	1,096	1,184
Daandine Utility Dam	Utility	26	31	48
Daandine CGPF Dam	CGPF	16	18	20
Kogan North Aggregation Dam	Aggregation	261	299	427

**Table 4-2 Tipton Water Management Network Storages**

Dam Name	Type	Volume at Design Storage Allowance (ML)	Volume at Mandatory Reporting Level (ML)	Volume at Spillway (ML)
Tipton Aggregation Dam 1	Aggregation	1,096	1,443	1,240
Tipton Aggregation Dam 2	Aggregation	1,781	2,046	1,728
Tipton Feedwater Dam	Aggregation	357	422	388
Tipton Treated Water Dam	Treated	367	422	404
Tipton Brine Dam	Brine	879	1,141	989
Tipton Utility Dam	Utility	41	61	57
Tipton CGPF Dam	CGPF	1.8	2.7	3.3

**Table 4-3 Daandine Water Treatment Facilities**

Facility Type	Technology	Nameplate Throughput (ML/d)
Water Treatment Plant	MF/RO	12

**Table 4-4 Tipton Water Treatment Facilities**

Facility Type	Technology	Nameplate Throughput (ML/d)
Water Treatment Plant	MF/RO	12

# SGP CSG Water Management Plan

**Table 4-5 Daandine Beneficial Use Supply**

Status	Beneficial Use Offtake	Peak Daily Supply (ML/d)	DES Hierarchy Priority
Existing	Power Station	0.5	Priority 1
	Arrow Projects (construction and operational uses)	1	Priority 1
	Feedlot	0.6	Priority 1
	CASS	23.5 <sup>1</sup>	Priority 1

Notes:

1. CASS primarily supported by 23.5 ML/d capacity Treated Water Return Pipeline transfer from the Kenya WTF

**Table 4-6 Tipton Beneficial Use Supply**

Status	Beneficial Use Offtake	Peak Daily Supply (ML/d)	DES Hierarchy Priority
Existing	Arrow Projects (construction and operational uses)	1	Priority 1
	Feedlot	4	Priority 1

## 4.3.2 Kogan North Water Management Network

The Kogan North WMN does not contain any water assets, except for the water gathering network.

## 4.3.3 SGP North Water Management Network

SGP North contains the following water assets, in addition to water gathering and transfer pipelines.

**Table 4-7 SGP North CSG Water Storages**

Dam Name	Type	Volume at Design Storage Allowance (ML)	Volume at Mandatory Reporting Level (ML)	Volume at Spillway (ML)
Castledean Pilot Dam	Aggregation	173	195	216
Kedron Pilot Dam	Aggregation	151	175	195
Punchbowl Pilot Dam	Aggregation	222	231	264
Girraheeen WTS Feed Tank	Aggregation	N/A	N/A	N/A

# SGP CSG Water Management Plan

## 4.3.4 SGP South Water Management Network

SGP South contains the following water assets, in addition to water gathering and transfer pipelines.

**Table 4-8 SGP South CSG Water Storages**

Dam Name	Type	Volume at Design Storage Allowance (ML)	Volume at Mandatory Reporting Level (ML)	Volume at Spillway (ML)
Hillview Pilot Dam	Aggregation	373	383	465

## 4.3.5 Hopeland Water Management Network

The Hopeland development contains the following water assets, in addition to water gathering and transfer pipelines.

**Table 4-9 Hopeland CSG Water Storages**

Dam Name	Type	Volume at Design Storage Allowance (ML)	Volume at Mandatory Reporting Level (ML)	Volume at Spillway (ML)
Hopeland Pilot Dam	Aggregation	241	248	280

## 4.3.6 Kenya Pipeline and Brine Dam

The following section provides details of the Kenya Brine Dams.

**Table 4-10 Kenya Pipeline and Brine Dam Water Storages**

Dam Name	Type	Volume at Design Storage Allowance (ML)	Volume at Mandatory Reporting Level (ML)	Volume at Spillway (ML)
Arrow Concentrated Brine Pond	Brine	1566	1586	1748
Arrow Concentrated Brine Pond 2 (future) <sup>1</sup>	Brine	TBC	TBC	1500 Max

Notes:

- Arrow Concentrated Brine Pond 2 is approved under EA0001540 for a total scale of 1500 ML. Dam management volumes are subject to future design activities.

## 5. Risk Management

Arrow implements a standardised approach to risk management, enabling risks to be ranked and prioritised across all operations. Arrow's approach to risk management seeks to:

- Identify and understand risks inherent to the business; and
- Apply adequate risk response by:
  - Decreasing the likelihood and consequence of adverse effects;
  - Increasing the likelihood and impact of positive effects;
  - Implementing effective controls;
  - Setting boundaries for risk acceptance;
  - Focusing assurance activities towards the highest areas of risk.

An assessment of the risks related to CSG water management for the SGP was completed in March 2018 and reviewed in October 2023 and April 2026. The risk assessment used the Arrow Energy framework<sup>5</sup>. Table 5-1 summarises the most pertinent CSG water management risks for the SGP development, alongside mitigation measures that will control all risks to acceptable levels.

The risk assessment shows that:

- Most risks are ranked as Low considering existing management controls;
- Risks related to the failure of the WTP to achieve desired design water quality and the failure to deliver a long-term brine management solution ranked as Medium;
- For risks which ranked as Medium, the residual risk ranking is Low after consideration of risk response measures.

---

<sup>5</sup> Arrow Energy, 2018 Arrow Energy Risk Management Procedure, Appendix 1 - Risk Assessment Matrix, Version 5.0, Doc No: ORG-ARW-RMT-PRO-00001

# Plan

S00-ARW-PMC-PLA-00169

Table 5-1 Summary of Risk Assessment

Safe Work. Strong Business.



Hazard / Threat	Consequences	Existing Controls	Current Risk Ranking	Risk Response	Residual Risk Ranking
Dam Break – collapse of the structure due to any possible cause	Dam break has the potential to cause: harm to humans; harm to the environment; general economic loss or property damage; and non-compliance with EA conditions.	Dams are designed and operated in accordance with Queensland regulation. <sup>6</sup>  Monitoring and maintenance is undertaken in accordance with Dam Operating Plans.  Annual dam inspections conducted. Weekly operator inspections of dam levels.	LOW <i>Aggregation Dam</i>	Implementation of emergency procedures as defined in the Dam Operating Plans.	LOW <i>Aggregation Dam</i>
			LOW <i>Treated Water Dam</i>		LOW <i>Treated Water Dam</i>
			LOW <i>Brine Dam</i>		LOW <i>Brine Dam</i>
Failure to contain – seepage - significant changes to Groundwater from seepage	Seepage has the potential to cause: harm to humans; harm to the environment; general economic loss or property damage; and non-compliance with EA conditions.	Dams are designed and operated in accordance with Queensland regulation.  Regular monitoring of groundwater quality in the immediate vicinity of regulated dams as per the Groundwater Monitoring Program.  Seepage controls such as HDPE liners and collection systems are in place where risks are present.  Brine management dams include capability to capture any seepage that may pass through HDPE lining.  Monitoring and maintenance undertaken in accordance with Dam Operating Plans.	LOW <i>Aggregation Dam</i>	Implementation of emergency procedures as defined in the Dam Operating Plans.	LOW <i>Aggregation Dam</i>
			LOW <i>Treated Water Dam</i>		LOW <i>Treated Water Dam</i>
			LOW <i>Brine Dam</i>		LOW <i>Brine Dam</i>

<sup>6</sup> Department of Environment and Heritage Protection, Manual for Assessing Consequence Categories and Hydraulic Performance of Structures, DETSI, Queensland, Australia (ESR/2016/1933).

Once printed, this is an uncontrolled document unless issued and stamped Controlled Copy.



## SGP CSG Water Management Plan

Hazard / Threat	Consequences	Existing Controls	Current Risk Ranking	Risk Response	Residual Risk Ranking
Failure to Contain – overtopping – releases due to overtopping of the structure	Overtopping has the potential to cause: harm to humans; harm to the environment; general economic loss or property damage; and non-compliance with EA conditions.	Dams are designed and operated in accordance with Queensland regulation.  Operation of storages in accordance with dam operating plans and EA conditions.  Adherence to DSA and MRL operating rules.  Release reduction strategy in place including production forecasting and water balance model scenario testing.  Emergency spillways on dams.	LOW	Implementation of emergency procedures (including emergency discharge strategy) as defined in the Dam Operating Plans.	LOW
Failure of water treatment plant to achieve required water quality	Plant failure has the potential to cause: an inability to use treated CSG water for intended beneficial use options; and non-compliance with EA conditions.	Upstream buffer storage to allow for temporary system shut down to resolve potential issues.  Automated monitoring within the WTP system to allow for early detection and mitigation of issues.  Automated water quality sampling in permeate dam prior to beneficial use.	LOW	Water treatment plant upgrades (including pre and post treatment systems) or replacements to achieve water quality objectives.  Option to turn down / shut in wells if upstream storage becomes limiting.	LOW
Failure to secure water off-takes	Insufficient off-takes have the potential to require disposal of CSG water instead of beneficial use.	CSG water utilisation portfolio to be maintained with sufficient capacity (above upper bound water production curves) to address this risk.  Existing irrigation offtakes as part of the CASS.  Ability to provide excess capacity into existing SunWater beneficial use pipeline to Chinchilla weir.	LOW	Market analysis and identification of new / additional off-take opportunities.	LOW

## SGP CSG Water Management Plan

Hazard / Threat	Consequences	Existing Controls	Current Risk Ranking	Risk Response	Residual Risk Ranking
Failure to deliver long-term brine management solution.	No long-term brine management solution has the potential to: require additional brine storage construction when existing capacity is exhausted; increase operational footprint and create additional impact on environmental receptors; and require utilisation of 3 <sup>rd</sup> party treatment and/or disposal services	Brine feasibility studies have been undertaken to identify a feasible long term brine management solution  Construction of additional brine storage dams to account for short term needs.	MEDIUM <sup>7</sup>	Alternative salt management options will be periodically reviewed to confirm the selected option.  Ongoing engagement with Industry and DETSI.	LOW

<sup>7</sup> Risk ranks as moderate due to increased costs to deal with residual brine.

## 6. Management Criteria

### 6.1 Measurable Criteria

Arrow Energy has defined Measurable Criteria for the SGP in accordance with Section 126 (1) of the EP Act 1994. To ensure criteria are targeted towards those CSG water management activities and elements that require greatest control, they have been developed from the outcomes of the risk assessment described in Section 5. The Measurable Criteria will be used to monitor and assess the effectiveness of CSG water management across a range of indicators and will be reported in the annual return when required.

Table 6-1 presents the measurable criteria required to satisfy the requirements of the EP Act. The criteria will be re-evaluated if required as a result of changes in the way which Arrow manages CSG water.

# Plan

S00-ARW-PMC-PLA-00169

Table 6-1 Measurable Criteria

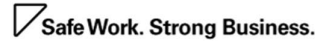
 Safe Work. Strong Business.



Management Component	Objectives	Environmental Value Protected	Controls	Measurable Criteria
Transmission of CSG water via pipelines	Effective containment of water throughout transmission activities from well to beneficial use / disposal.	Surface and groundwater quality. Soil quality (including structural and chemical properties).	Regular monitoring and maintenance in accordance with asset integrity and maintenance plan. Process safety in design and controls.	No reportable unplanned releases of CSG water.
Storage of CSG water in regulated dams	Effective containment of CSG water in dams. Regulated dams operated and maintained in accordance with approvals.	Surface and groundwater quality. Soil quality (including structural and chemical properties).	Dam designed and constructed as per relevant guidelines and regulations. Annual dam integrity inspections. Groundwater monitoring program. Scheduled maintenance of infrastructure and facilities. Dam operating plans. Water balance modelling to develop operating philosophy and strategy.	Water level below DSA at Nov-1 <sup>8</sup> . No breaches of MRL. Annual inspections completed. No unplanned releases.
Beneficial Use	Maximise beneficial use of CSG water. Ensure that supplied beneficial use water is in accordance with approvals.	Surface and groundwater quality. Soil quality (including structural and chemical properties).	Regular monitoring of the qualities and quantities of water supplied for beneficial use. Scheduled maintenance of infrastructure and facilities. CSG Water and Salt Management Strategy.	Water supply agreements in place. Water quality for beneficial use meets approval conditions.

<sup>8</sup> If the dam is a regulated structure as per the failure to contain overtopping scenario in the *Queensland Department of Environment and Heritage Protection, Manual for Assessing Consequence Categories and Hydraulic Performance of Structures*, DEHP, Queensland, Australia (ESR/2016/1933).

Once printed, this is an uncontrolled document unless issued and stamped Controlled Copy.



## SGP CSG Water Management Strategy

Management Component	Objectives	Environmental Value Protected	Controls	Measurable Criteria
Management of salt and brine	Management of salt in accordance with the regulatory framework.	Land use capability, having regard to economic considerations. Surface and ground water quality. Soil quality (including structural and chemical properties).	Continual assessment of feasible options for beneficial use and/or disposal of salt in accordance with the CSG Water Management Policy 2012. Containment of salt and brine in fit for purpose storage infrastructure operated and maintained in accordance with approvals.	Water level below DSA at Nov 1 <sup>9</sup> . No breaches of MRL. Annual inspections completed. No reportable unplanned releases.

<sup>9</sup> If the dam is a regulated structure as per the failure to contain overtopping scenario in the *Queensland Department of Environment and Heritage Protection, Manual for Assessing Consequence Categories and Hydraulic Performance of Structures*, DEHP, Queensland, Australia (ESR/2016/1933).

### 6.2 Response Procedures

Should any of the Measurable Criteria in Table 6-1 not be met, the following response procedure will be implemented:

- Where relevant, reporting of incident in line with the relevant Environmental Authority requirements;
- Evaluation (including root cause analysis) of the underlying cause of the criteria not being met;
- Review of relevant procedures, protocols and management plans and make changes where required;
- Implementation of corrective actions to address underlying cause. This, for example, could include:
  - Engineering solutions;
  - Amendments to operating procedures; and/or
  - Change to management process.

### 6.3 Arrow Operating Procedures

Arrow Energy commits its staff to the adoption of a series of standards, procedures and operating plans that control important elements of CSG water management. These include:

- Standards (ORG-ARW-HSM-STA-00001)
  - *Coal Seam Gas Water Standard*
  - *Chemical Management Standard*
  - *Waste Standard*
  - *Land Management Standard*
  - *Incident Management Standard*
- Procedures & Strategies
  - *Surat Gas Project CSG Water Management Strategy (WMS) (ORG-ARW-ENV-STR-00001)*
  - *Chemical Management Procedure (ORG-ARW-HSM-PRO-00016)*
  - *Waste Management Procedure (ORG-ARW-HSM-PRO-00066)*
  - *Land Rehabilitation Procedure (ORG-ARW-HSM-PRO-00073);*
  - *HSE Incident Management Procedure (ORG-ARW-HSM-PRO-00089)*
- Dam Operating Plans
  - *Surat Water Handling – DXP Dam Operating Plan (19-W-PL-0001),*
  - *Surat Water Handling – Aggregation Dams SGP Operating Plan (S00W01-ARW-AOP-PLA-00001)*

Each of Arrow Energy's standards, procedures and plans are reviewed regularly in order to ensure that all operating factors are considered, and that procedures continue to reflect latest understanding.

## 7. Monitoring

### 7.1 Environmental Monitoring

#### 7.1.1 Surface Water

Contingency discharge of treated CSG water to watercourses is a potential option in the event that other beneficial uses of CSG water are temporarily unavailable. Prior to the release of treated CSG water to a watercourse, Arrow will develop a Receiving Environment Monitoring Plan (REMP) to monitor, identify and describe any adverse impacts to surface water environmental values, water quality, and flows due to authorised releases. The REMP will be developed in accordance with granted EA conditions. Arrow does not currently have any installed watercourse release infrastructure.

#### 7.1.2 Groundwater

The Groundwater Monitoring Program will provide for the early detection of significant risks and changes in groundwater quality and levels as a result of activities authorised under the relevant EAs.

The Groundwater Monitoring Program may include:

- regular monitoring of groundwater quality in the immediate vicinity of regulated dams;
- monitoring of background sites;
- monitoring of dam water quality;
- establishment of site-specific environmental values for the shallow groundwater system;
- development of site-specific trigger values;
- ongoing monitoring of groundwater to identify environmental impacts; and
- implementation of management actions in the event of environmental impact.

Monitoring groundwater quality at dam sites requires installation of monitoring bores in close proximity to dams. The exact location of these bores is guided by geotechnical investigations to identify the direction in which groundwater impact is likely to travel. Background sites are also installed at distances of 500m to 1,500m (where access allows) both up and down gradient of the dams.

Site-specific trigger levels are developed by considering the background groundwater quality, established trigger levels (such as ANZECC water quality criteria), and the potential impacts of seepage from regulated dams. Ongoing monitoring is then used to identify whether, and to what extent, environmental impacts, with reference to the aforementioned criteria, are occurring. Where unacceptable impacts have occurred, management actions are initiated to remedy these.

### 7.2 Monitoring of CSG Water Management Dams

In accordance with dam operating plans, Arrow Energy will conduct the following monitoring:

- Dam water levels monitored against MRL and DSA;
- Visual inspections for algae, surface slicks or fauna interaction;

## SGP CSG Water Management Strategy

- Visual structural inspection for early identification of integrity issues;
- Identification of any changes to the dam service/contents;
- Groundwater impact monitoring for physico-chemical parameters;
- Each regulated dam will be inspected by a suitably qualified and experienced person with an Annual Inspection Report prepared and certified; and
- An assessment of the DSA will be undertaken on or before 1 November each year.

## 8. Reporting

### 8.1 Annual Return

In accordance with the requirements of the SGP EAs, Arrow Energy will complete and submit an Annual Return which will include an evaluation of the effectiveness of the management of CSG water under the criteria described in Section 126(1)(e) of the EP Act.

### 8.2 Annual Inspection Report

Arrow Energy will undertake inspection and reporting for each of its regulated structures in accordance with the relevant EAs. Annual Inspection Report(s) will be certified by a suitably qualified and experienced person.

### 8.3 Annual Monitoring Report

An Annual Monitoring Report summarising monitoring results over the previous 12 month period will be prepared and made available to DETSI upon request. All monitoring results will be retained for no less than five years.

### 8.4 Incident Reporting

If any contaminant levels are identified as having caused, or have the potential to cause environmental harm, this will be reported to DETSI in accordance with EP Act and EA requirements.

## 9. Document Administration

This document has been created using ORG-ARW-IMT-TEM-00010 v5.0

### Revision history

Revision	Revision Date	Revision Summary	Author
1.0	May 2018	IFU	Senior Water Planner
1.1	04/10/2023	IFR	Principal Concept Engineer
2.0	17/11/2023	IFU	Principal Concept Engineer
3.0	28/04/2026	IFU	Principal Concept Engineer

### Controlled document location

Assai

### Related documents

Document Number	Document title
99-W-PL-0010 (superseded)	Surat Gas Project CSG Water Management Plan
ORG-ARW-ENV-STR-00001	SGP CSG Water Management Strategy

### Acceptance and release

#### Author

Position	Release Date
Principal Concept Engineer	28/04/2026

#### Approver(s)

Position	Approval Date
Concept Engineering Manager	28/04/2026